

# BCA610

## AC Source Battery Charger

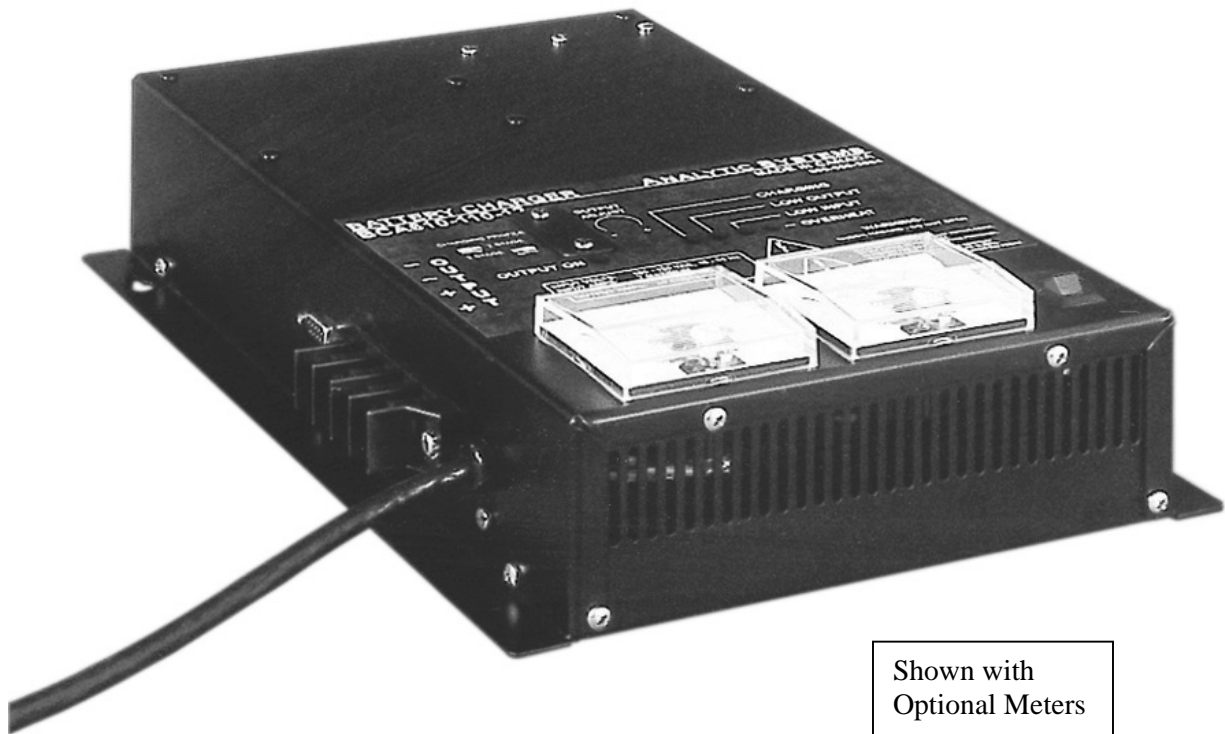

Shown with  
Optional Meters

## Installation & Operation Manual

---

# ANALYTIC SYSTEMS

Tel (604) 543-7378; Fax (604) 543-7354

Toll Free 1-800-668-3884 US & CANADA

# IMPORTANT SAFETY INSTRUCTIONS

- 1) **SAVE THESE INSTRUCTIONS** — This manual contains important safety and operating instructions for battery charger
- 2) Do not expose battery charger to rain or snow.
- 3) Use of an attachment not recommended or sold by the battery charger manufacturer may result in a risk of fire, electric shock, or injury to persons.
- 4) Do not disassemble battery charger ; take it to a qualified serviceman when service or repair is required. Incorrect reassembly may result in a risk of electric shock or fire.
- 5) To reduce risk of electric shock, unplug battery charger from outlet before attempting any maintenance or cleaning. Turning off controls will not reduce this risk.
- 6) Never place battery charger directly above battery; gases from battery will corrode and damage battery charger.
- 7) Never allow battery acid to drip on battery charger when reading gravity or filling battery.

## ALL BATTERY CHARGERS

### 1) WARNING — RISK OF EXPLOSIVE GASES.

i) WORKING IN VICINITY OF A LEAD-ACID BATTERY IS DANGEROUS. BATTERIES GENERATE EXPLOSIVE GASES DURING NORMAL BATTERY OPERATION. FOR THIS REASON, IT IS OF UTMOST IMPORTANCE THAT EACH TIME BEFORE SERVICING EQUIPMENT IN THE VICINITY OF THE BATTERY, YOU READ THIS MANUAL AND FOLLOW THE INSTRUCTIONS EXACTLY.

ii) To reduce risk of battery explosion, follow these instructions and those published by battery manufacturer and manufacturer of any equipment you intend to use in vicinity of battery. Review cautionary marking on these products and on engine.

### 2) PERSONAL PRECAUTIONS

i) Someone should be within range of your voice or close enough to come to your aid when you work near a lead-acid battery.

ii) Have plenty of fresh water and soap nearby in case battery acid contacts skin, clothing, or eyes.

iii) Wear complete eye protection and clothing protection. Avoid touching eyes while working near battery.

iv) If battery acid contacts skin or clothing, wash immediately with soap and water. If acid enters eye, immediately flood eye with running cold water for at least 10 minutes and get medical attention immediately.

- v) NEVER smoke or allow a spark or flame in vicinity of battery or engine.
- vi) Be extra cautious to reduce risk of dropping a metal tool onto battery. It might spark or short-circuit battery or other electrical part that may cause explosion.
- vii) Remove personal metal items such as rings, bracelets, necklaces, and watches when working with a lead-acid battery. A lead-acid battery can produce a short-circuit current high enough to weld a ring or the like to metal, causing a severe burn.
- viii) NEVER charge a frozen battery.
- ix) If necessary to remove battery from service, always remove grounded terminal from battery first. Make sure all accessories in the vessels are off, so as not to cause an arc.
- x) Be sure area around battery is well ventilated.
- xi) Clean battery terminals. Be careful to keep corrosion from coming in contact with eyes.
- xii) Study all battery manufacturer's specific precautions such as removing or not removing cell caps while charging and recommended rates of charge.
- xiii) Add distilled water in each cell until battery acid reaches level specified by battery manufacturer. This helps purge excessive gas from cells. Do not overfill. For a battery without cell caps, carefully follow manufacturer's recharging instructions.

**GROUNDING AND AC POWER CORD CONNECTION INSTRUCTIONS** — The plug must be plugged into an outlet that is properly installed and grounded in accordance with all local codes and ordinances.

**DANGER** — Never alter AC cord or plug provided — if it will not fit outlet, have proper cord installed by a qualified electrician. Improper connection can result in a risk of an electric shock.

**Analytic Systems** does not recommend the use of the BCA610 Series Battery Chargers in life support applications where failure or malfunction of this product can be reasonably expected to cause failure of the life support device or to significantly affect its safety or effectiveness. **Analytic Systems** does not recommend the use of any of its products in direct patient care.

Examples of devices considered to be life support devices are neonatal oxygen analyzers, nerve stimulators (whether used for anesthesia, pain relief, or other purposes), autotransfusion devices, blood pumps, defibrillators, arrhythmia detectors and alarms, pacemakers, hemodialysis systems, peritoneal dialysis systems, neonatal ventilator incubators, ventilators for both adults and infants, anesthesia ventilators, and infusion pumps as well as any other devices designated as "critical" by the U.S. FDA.

# INTRODUCTION

The model BCA610 Battery Charger charges either 12, 24, 32 or 48 batteries from a 110 or 220 VAC power source. Other battery voltages up to 72 volts are also available by special order. The all new Current Mode switching design offers increased power and reliability in a compact package. Extra input and output filtering reduce EMI to extremely low levels. Reliability features include an input fuse, thermal shutdown, current limiting, reverse battery hookup protection and output short circuit shutdown with automatic recovery. The output voltage is easily adjusted 0.5 volts above or below the standard output voltage to accommodate special charging requirements. 1 or 2 high quality analog meters can be added (factory option) to allow monitoring of charging current and charging voltage.

## BCA610-ip-op Specifications

### Input Voltages

<b>Nominal (ip)</b>	110	220
<b>Actual (Vac)</b>	105 - 125	210 - 250
<b>Frequency (Hz)</b>	45 - 65	
<b>Input Amps (max)</b>	8	4
<b>Input Fuse</b>	MDA 10A (Slow Blow)	MDA 5A (Slow Blow)

### Output Voltages

<b>Nominal (op)</b>	12	24	32	48
<b>Float (Vdc)</b>	13.6 ± 0.05	27.2 ± 0.05	36.3 ± 0.05	54.4 ± 0.05
<b>Absorption Voltage (Vdc)</b>	14.4	28.8	38.4	57.6
<b>Charging Amps</b>	40	22	16.5	11
<b>Absorption to Float</b>	4.0 Amps	2.2 Amps	1.65 Amps	1.1 Amps
<b>Battery Size (Amp Hours)*</b>	160 – 240	88 – 132	66 – 99	44 - 66
<b>Output Crowbar</b>	16.0 ± 0.5 V	32.0 ± 1.0 V	42.7 ± 1.3 V	63.9 ± 2.0 V
<b>Output Fuses (ATC)</b>	40 x 2	30 x 2	20 x 2	15 x 2

### General

<b>Battery Banks</b>	1 or 2
<b>Stages</b>	2 or 3
<b>Noise on Input</b>	< 50 milli-volts
<b>Noise on Output</b>	< 50 milli-volts
<b>Transient Resp.</b>	< 2V for 10A Surge
<b>Efficiency</b>	> 75 % @ maximum output
<b>Temp. Range</b>	0 – 40° C @ maximum output
<b>Isolation</b>	Input-Case & Input-Output 1500 VDC, Output-Case 500 VDC
<b>Length</b>	14.5 in / 36.8 cm
<b>Width</b>	9.9 in / 25.1 cm
<b>Height</b>	3.0 in / 14.0 cm
<b>Clearance</b>	1 Inch (2.5 cm) all around
<b>Material</b>	Marine Grade Aluminum
<b>Finish</b>	Black Anodize / Black Powder Epoxy
<b>Fastenings</b>	18-8 Stainless
<b>Weight</b>	7.2 lb / 3.3 kg

\* This is Analytic Systems' suggested range. Please consult your battery manufacturer for their recommendations.

designed and manufactured by:

**ANALYTIC SYSTEMS WARE (1993) LTD.**

#207 12448 82 Ave. Surrey, B.C., V3W 3E9, Canada

phone (604) 543-7378 fax (604) 543-7354

**toll free 800-668-3884 US/Canada**

email: info@analyticssystem.com; web site: www.analyticssystem.com

Rev. Nov 2000

Specifications subject to change without notice.

# INSTALLATION

## MOUNTING

Mount the unit in a DRY location. Allow at least 4 inches of clearance around the heat sink fins for adequate cooling.

## POWER CONNECTION

The unit is supplied with a 5 foot power cable. This should normally be adequate to connect to a source of power. If you must extend the power cable be sure to use a 3 conductor grounded type extension cable. For hard wiring to a source of power, cut off the plug, and strip the wires as necessary. The wire colours are

110 VAC	220 VAC
Black - AC Hot	Black - Phase 1
White - AC Neutral	White - Phase 2
Green - Ground	Green - Ground

All connections should be made inside an appropriate junction box. The maximum current draw from a 110 VAC source is 7.6 amps, so a 10 amp circuit breaker should be used in the circuit panel. For a 220 VAC source, 3.8 amps is the maximum current draw, so a 5 amp circuit breaker should be used in the circuit panel to feed power to the BCA 610.

## OUTPUT CONNECTIONS

Two Positive output terminals and two Negative output terminals are provided. Connect only one wire to each terminal. Ensure that the total average load connected to the batteries does not exceed the continuous current rating of the unit.

To ensure **spark free connections** the power switch must be in the **OFF** position prior to making the connections to the battery bank(s).

The unit may be hooked to 1 or 2 battery banks depending on the model. Hook up the battery bank(s) as shown below. If you are hooking up 2 battery banks keep in mind that they **MUST** share a common ground!

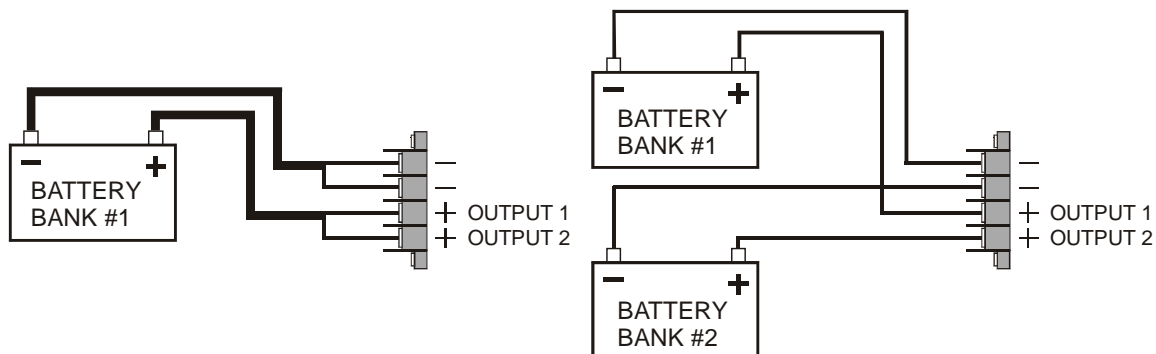

## METERS

1 or 2 high quality 2 ½ inch analog meters can be added to the charger (factory installed only). 1 ammeter allows monitoring of total charging current. 2 ammeters allow independent monitoring of the current into each of 2 battery banks. 1 ammeter and 1 voltmeter allow monitoring of total charging current and shows the voltage of the most discharged battery bank (if 2 banks are being charged).

## OPERATION

Prior to turning on the unit, you must decide on which charging profile, 2 or 3 stage charging, to use. To help you decide, please see the following section entitled 2 or 3 Stage Charging to determine the charging profile.

Once you have decided on the charging profile you must set the switch to the correct position. To access the switch, remove the cover plate (secured by 2 screws). Set the switch to the correct position as shown on the label. When you are done, replace the cover plate and securely tighten the screws.

To turn the unit on, simply move the power switch to the ON position. The alarm buzzer will sound and the Low Output LED will come on briefly, and then the green OUTPUT ON LED will illuminate.

When the unit is first turned on, it will charge the batteries at maximum current and the charging light will be on. After a period of time which may be minutes to hours, the batteries will reach the absorption voltage (3-stage) or float voltage (2-stage), and the charging current will reduce as necessary to maintain the batteries at that voltage. Once the charging current has dropped to a low level (about 10% of the charging current rating), the charging light will go off, and if set to 3-stage charging the voltage will drop to the float level. You may check this voltage at the output terminals of the unit with a good digital voltmeter. As shipped from the factory, the unit is preset for a float voltage of 13.6, 27.2, 36.3 or 54.4 VDC, which is generally recommended for lead-acid batteries. If you wish to adjust this voltage, remove the cover plate (secured by 2 screws) to expose the Output Adjust potentiometer. Reach in with a very small flat blade screwdriver to rotate the potentiometer. **Please note that this adjusts both the float and absorption voltages at the same time.** Clockwise increases the output voltage and counter clockwise decreases it. When you are done, replace the cover plate and securely tighten the screws. It is advisable to check with the battery manufacturer before changing the float voltage.

### 2 or 3 Stage Charging:

There are many kinds and capacities of battery chargers. However, there are three major types: one-stage, two-stage and three-stage chargers.

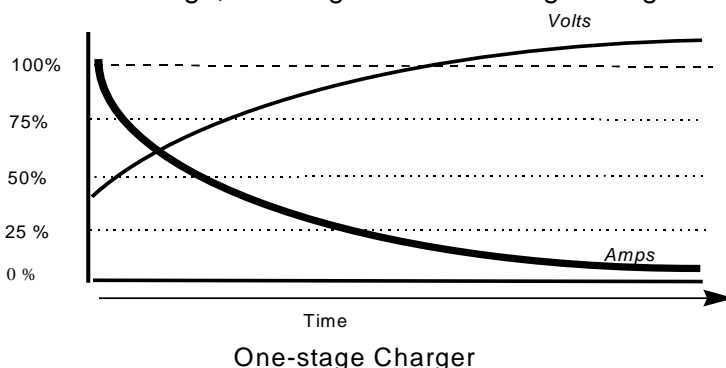

The ordinary one-stage charger is inexpensive but it charges slowly and cannot completely re-charge a battery to its rated capacity. There are no automatic voltage or current shifts during the charge cycle and without monitoring, overvoltage and water loss can cause premature battery failure.

Analytic Systems does not make nor recommend one-stage chargers because they can warp a battery's plates, effectively destroying it. Either a two or three-stage charger is recommended because it adjusts current and voltage according to the battery's requirements.

The choice is between a two or three-stage charger, depending upon its use:

- If there are permanent or transient loads on the battery during charging, a two-stage has the advantage because its circuits cannot be “fooled” into pushing a higher “absorption” voltage than required for charging.
- Without loads during charging, the three-stage has the advantage because it charges faster.

A two-stage charger provides a constant current until the battery reaches its rated capacity and then switches to a “float” voltage. The current then reduces as necessary to maintain the battery at the float voltage. The charger can be connected to the battery indefinitely and will provide the appropriate profile. A two-stage charger is recommended in most instances since it is the most versatile and can be permanently connected to attenuate the characteristic discharge of unused batteries. A load can be put on the battery or batteries without altering its ability to keep the battery at optimal charge.

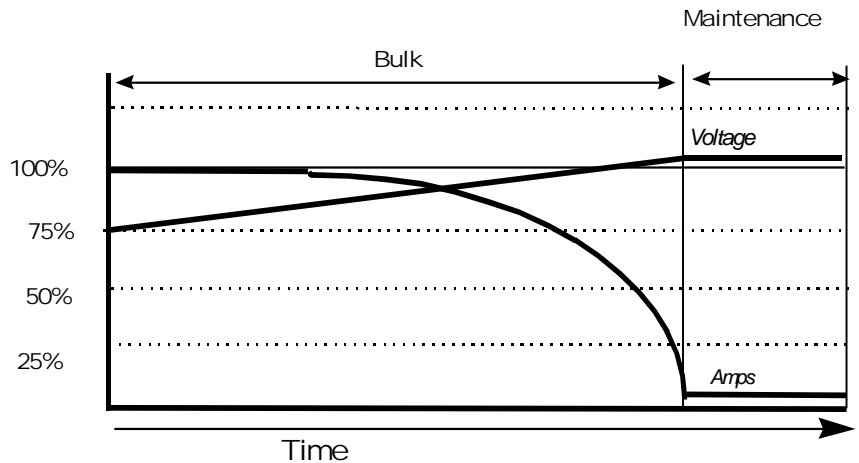

Two-Stage Charger

A three-stage charger is the fastest charger. It charges the battery at a constant current until the battery voltage reaches a slightly elevated level. The battery is maintained at this voltage while the charging current diminishes to a low value, and then the battery is switched to the float voltage where it can be maintained indefinitely. However, the charger cannot differentiate between a current going to a load on the battery, or being absorbed by the battery, so it can overcharge a battery supplying current to a load. A two-stage charger is preferred for “loaded” batteries and a three-stage for idle or unloaded batteries during recharging.

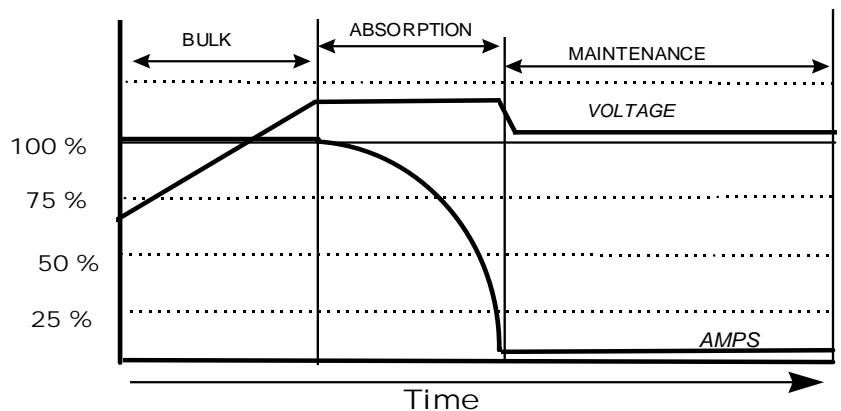

Three-Stage Charger

All of Analytic Systems’ chargers include adjustable output voltage for charging standard or deep cycle lead-acid, VLRA or gel type batteries.

## TROUBLE SHOOTING

This unit provides LED indicators and a buzzer to help diagnose any problems. The unit should sound the buzzer to alert you prior to shutting itself down. You should immediately check the indicators to determine the cause of the shutdown.

- **LOW OUTPUT** Indicates that the output voltage is below normal because:
  - The current demanded by the devices connected to the unit exceeds the maximum output current rating, thereby causing the output voltage to drop to maintain the current at the maximum level,
  - The input voltage is not high enough for unit to operate,
- **LOW INPUT** Indicates that the input voltage is below normal because:
  - The input voltage is not in the correct range for proper operation of the unit.
- **OVERHEAT** Indicates that the battery charger is running too hot because:
  - Too much power is being drawn, turn off or unplug some devices.
  - The battery charger is located in a poorly ventilated area.
- **CHARGING** Indicates that the battery charger is charging the batteries:
  - If the LED is not on, the batteries may be fully charged and the charger is supplying a float voltage to the batteries to keep them fully charged

If the load exceeds the continuous rating for too long a period, the temperature sensor inside the unit will turn off the outputs. After the unit cools sufficiently, it will automatically come back on. If this happens frequently, remount the unit for increased airflow so it cools better.

## Dry Contact Relay

To use your dry contact output fail relay you must connect a 9-pin D connector to the unit. You must use pins one and six as is indicated on page 9 in the remote connector diagram.

The relay is factory preset to fail in the closed position when the low output LED and buzzer come on. If you wish to have the relay fail in the open position when the low output LED and buzzer come on, you must take the cover off the unit and move the jumper to the other position on J22. J22 is located next to the relay.



**To change the position of the jumper, first turn the unit off and disconnect the unit from both the power and batteries. Next, turn the unit on for 30 seconds to discharge the capacitors, then turn it off again. Turn the unit upside down and remove the four screws. Remove the cover and locate J22. It will be next to the relay as is shown in the above diagram. Simply move the jumper to the desired position as is shown in the above diagram. Replace the cover and re-install the four screws. Reconnect the unit to the power and batteries.**

## REMOTE CONNECTOR

This connector is located on the side of the unit.

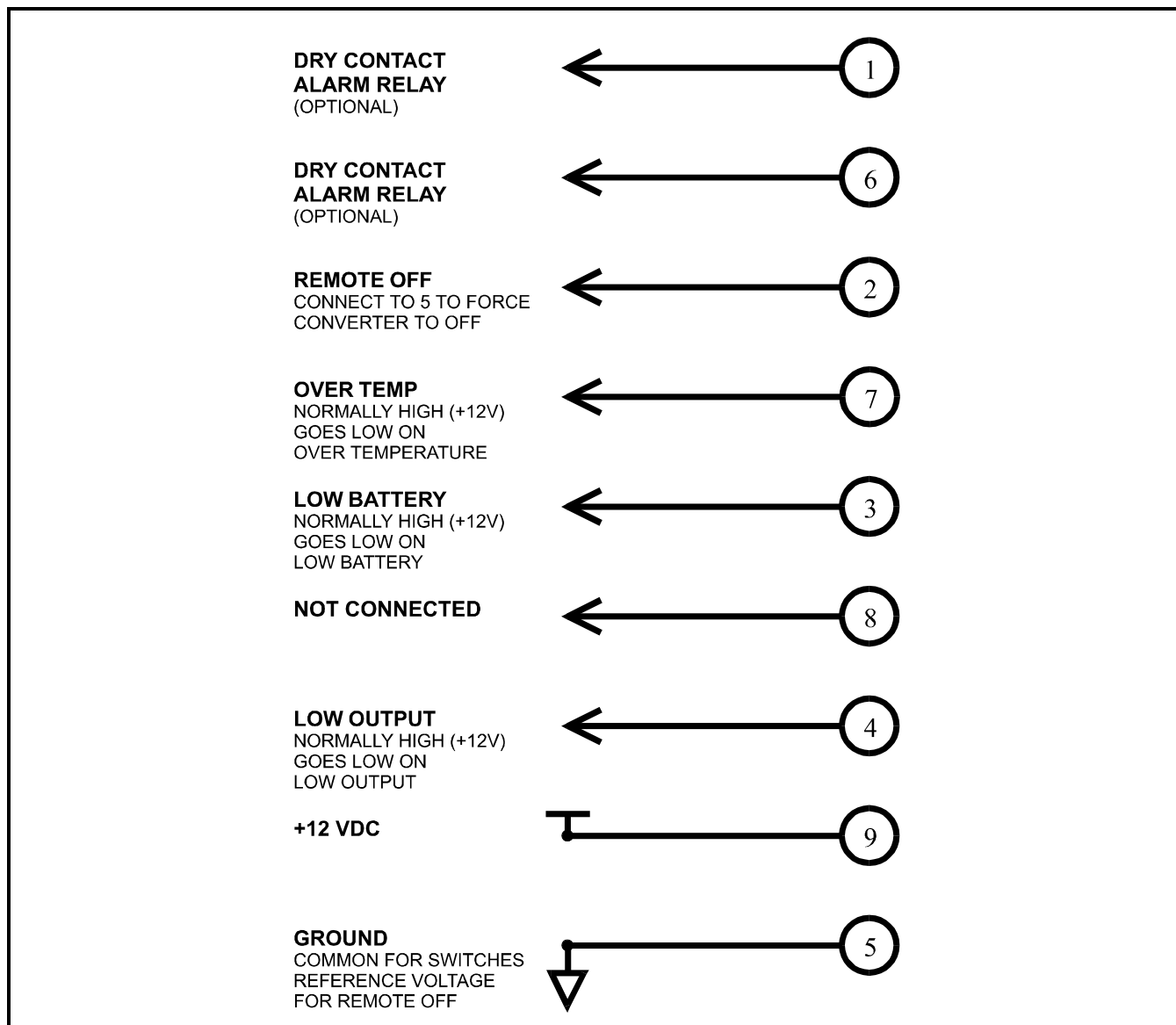

Note: All switches are electronic (solid state) not mechanical relays.

## REMOTE CONTROL

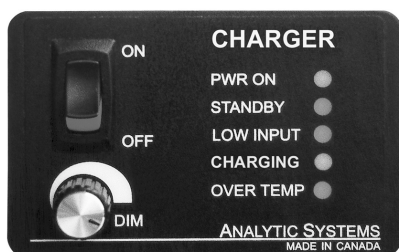

A remote control panel may be connected to the battery charger using a 9-pin D-connector which attaches to the side of the battery charger. The remote control panel and D connector are part of the remote control option. The remote control panel allows the unit to be operated remotely as well as duplicating all the diagnostic indicators and audible alarm.

## Equalize Option

The purpose of the Equalize Option is to deliberately overcharge the battery at a low rate of current to ensure that all cells are fully charged and to reduce the chance of sulfation of the battery. During the Equalize cycle, the cells, which are fully charged, will produce Hydrogen gas, and the cells, which are undercharged, will be brought up to full charge. An Equalize cycle should be done once every 2-3 months, or whenever battery capacity appears to be diminished. The Equalize Option also includes a battery temperature sensor to compensate the charging voltage for battery temperature, as well as to shut the charger down if the battery should become overheated. A 2<sup>nd</sup> temperature sensor can be added to allow monitoring of both batteries if the charger is connected to 2 banks of batteries.

An Equalize cycle can be initiated at any time by simply pressing the equalize start button located next to the ON/OFF switch. This button is deliberately recessed to prevent accidental operation. It is most easily pressed by using a ballpoint pen. If the charger is in the middle of charging the battery (the Charging LED is on), the Equalize LED will flash. Once the main charging cycle is complete, the Equalize cycle will begin and the Equalize LED will stay on all the time. If the Charging LED is off when the button is pressed, the Equalize cycle will begin immediately.

The charger will charge the battery at approximately 1/3<sup>rd</sup> its normal rate (i.e. 13 amps for a 40 amp charger) until the battery reaches a maximum voltage of 15.5 volts (31.0 volts for a 24V battery, etc.) and then reduce the current as necessary to maintain the battery at that voltage. Three hours after the Equalize cycle begins, the charger will return to the float mode where the battery can be maintained indefinitely. If the battery temperature reaches 120 degrees F (50 degrees C) the equalize cycle will end and the charger output reduced to a very low voltage until the battery cools, and then the charger will return to the float mode.

## Remote Battery Temperature Sensor Installation

The remote battery temperature sensor allows the monitoring of the battery bank so that the charging profile can be adjusted to optimally charge the battery bank depending on the temperature of the battery bank.

The battery temperature sensor may be installed in many different ways, so long as the sensor stays in contact with the battery. The preferred method is as follows:

The batteries to be charged will be placed on a platform made of wood. Prior to placing the batteries on the wooden platform a cavity is hollowed out such that the sensor will fit inside the cavity and be flush with the battery. Place the sensor inside the cavity facing the proper way (this is shown on the sensor). Next connect the sensor wiring to the DB9 connector marked "**EQUALIZE**" on the side of the unit.

If a battery blanket is used the sensor may be tucked inside the blanket with the proper side of the sensor facing the battery. The sensor may be placed on top of the battery but it should be secured to the battery so as to prevent it from losing contact with the battery.

# Limited Warranty

1. The equipment manufactured by Analytic Systems Ware (1993) Ltd. (the "Warrantor") is warranted to be free from defects in workmanship and materials under normal use and service. This warranty is in effect for 3 years from the date of purchase by the user (the "Purchaser").
2. In case any part of the equipment proves to be defective, the Purchaser should do the following:
  - a) Prepare a written statement of the nature of the defect to the best of the Purchasers knowledge, and include the date of purchase, the place of purchase, and the Purchasers name, address and telephone number.
  - b) Call Analytic Systems at 1-800-668-3884 or 604-543-7378 and request a return material authorization number (RMA).
  - c) Return the defective part or unit along with the statement at the Purchasers expense to the Warrantor; Analytic Systems Ware (1993) Ltd., #207 12448 82nd Ave., Surrey, B.C., V3W 3E9, Canada.
3. If upon the Warrantor's examination the defect proves to be the result of defective material or workmanship, the equipment will be repaired or replaced at the Warrantor's option without charge, and returned to the Purchaser at the Warrantor's expense.
4. No refund of the purchase price will be granted to the Purchaser, unless the Warrantor is unable to remedy the defect after having a reasonable number of opportunities to do so.
5. Warranty service shall be performed only by the Warrantor. Any attempt to remedy the defect by anyone else shall render this warranty void.
6. There shall be no warranty for defects or damages caused by faulty installation or hook-up, abuse or misuse of the equipment including exposure to excessive heat, salt or fresh water spray, or water immersion except for equipment specifically stated to be waterproof.
7. No other express warranty is hereby given and there are no warranties which extend beyond those described herein. This warranty is expressly in lieu of any other expressed or implied warranties, including any implied warranty of merchantability, fitness for the ordinary purposes for which such goods are used, or fitness for a particular purpose, or any other obligations on the part of the Warrantor or its employees and representatives.
8. There shall be no responsibility or liability whatsoever on the part of the Warrantor or its employees and representatives for injury to any person or persons, or damage to property, or loss of income or profit, or any other consequential or resulting damage which may be claimed to have been incurred through the use or sale of the equipment, including any possible failure of malfunction of the equipment, or part thereof.
9. The Warrantor assumes no liability for incidental or consequential damages of any kind.